

Hex Key

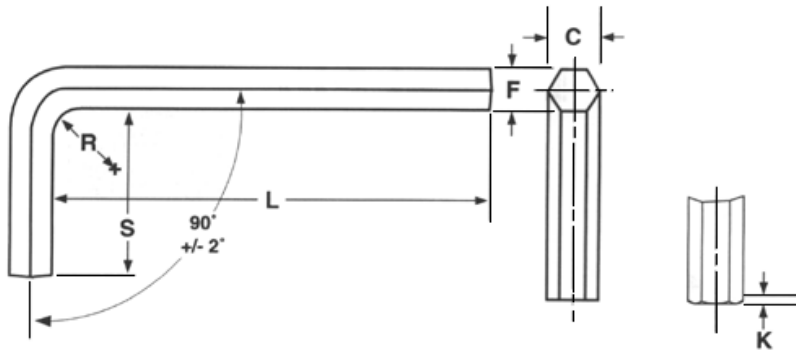

1/4" Short Arm Hex Import = HKS1/4
 2" Long Arm Hex Import = HKL2

1/4" Short Arm Hex Domestic = HKS1/4D
 2" Long Arm Hex Domestic = HKL2D

Less than 3/8 - HRC 48 Min
 Greater than or equal to 3/8 - HRC 45 Min

Nominal Size	F		C		S		L				R	K
	Key Size Across Flats		Across Corners		Short Arm		Long Arm				Radius	Chamfer
	Max	Min	Max	Min	Max	Min	Short Series		Long Series			
	0.028	0.0275	0.0314	0.0300	0.312	0.125	1.312	1.125	2.688	2.500	0.062	0.003
	0.035	0.0345	0.0393	0.0378	0.438	0.250	1.312	1.125	2.766	2.578	0.062	0.004
	0.050	0.0490	0.0560	0.0540	0.625	0.438	1.750	1.562	2.938	2.750	0.062	0.006
1/16	0.062	0.0615	0.0701	0.0680	0.656	0.469	1.844	1.656	3.094	2.906	0.062	0.008
5/64	0.078	0.0771	0.0880	0.0859	0.703	0.516	1.969	1.781	3.281	3.094	0.078	0.008
3/32	0.093	0.0927	0.1058	0.1035	0.750	0.562	2.904	1.906	3.469	3.281	0.094	0.009
7/64	0.109	0.1079	0.1238	0.1210	0.797	0.609	2.219	2.031	3.656	3.469	0.109	0.014
1/8	0.125	0.1235	0.1418	0.1390	0.844	0.656	2.344	2.156	3.844	3.656	0.125	0.015
9/64	0.140	0.1391	0.1593	0.1566	0.891	0.703	2.469	2.281	4.031	3.844	0.141	0.016
5/32	0.156	0.1547	0.1774	0.1745	0.938	0.750	2.594	2.406	4.219	4.031	0.156	0.016
3/16	0.187	0.1860	0.2135	0.2105	1.031	0.844	2.844	2.656	4.594	4.406	0.188	0.022
7/32	0.218	0.2171	0.2490	0.2460	1.125	0.938	3.094	2.906	4.969	4.781	0.219	0.024
1/4	0.250	0.2485	0.2845	0.2815	1.219	1.031	3.344	3.156	5.344	5.156	0.250	0.030
5/16	0.312	0.3110	0.3570	0.3531	1.344	1.156	3.844	3.656	6.094	5.906	0.312	0.032
3/8	0.375	0.3735	0.4285	0.4238	1.469	1.281	4.344	4.156	6.844	6.656	0.375	0.044
4/16	0.437	0.4355	0.5005	0.4944	1.594	1.406	4.844	4.655	7.594	7.406	0.438	0.047
1/2	0.500	0.4975	0.5715	0.5650	1.719	1.531	5.344	5.156	8.344	8.156	0.500	0.050
9/16	0.562	0.5600	0.6420	0.6356	1.844	1.656	5.844	5.656	9.094	8.906	0.562	0.053
5/8	0.625	0.6225	0.7146	0.7080	1.969	1.781	6.344	6.156	9.844	9.656	0.625	0.055
3/4	0.750	0.7470	0.8580	0.8512	2.219	2.031	7.344	7.156	11.344	11.156	0.750	0.070
7/8	0.875	0.8720	1.0020	0.9931	2.469	2.281	8.344	8.156	12.844	12.656	0.875	0.076
1	1.000	0.9970	1.1470	1.1350	2.719	2.531	9.344	9.156	14.344	14.156	1.000	0.081
1 1/4	1.250	1.2430			3.250	2.750	11.500	11.000			1.250	0.092
1 1/2	1.500	1.4930			3.750	3.250	13.500	13.000			1.500	0.104
1 3/4	1.750	1.743			4.250	3.750	15.500	15.000			1.750	0.115
2	2.000	1.9930			4.750	4.250	17.500	17.000			2.000	0.126
2 1/4	2.250	2.2430			5.250	4.750	19.500	19.000			2.250	0.137
2 3/4	2.750	2.7420			6.250	5.750	23.500	23.000			2.750	0.159
3	3.000	2.9920			6.750	6.250	25.500	25.000			3.000	0.171

Per ANSI/ASME B18.3